

7

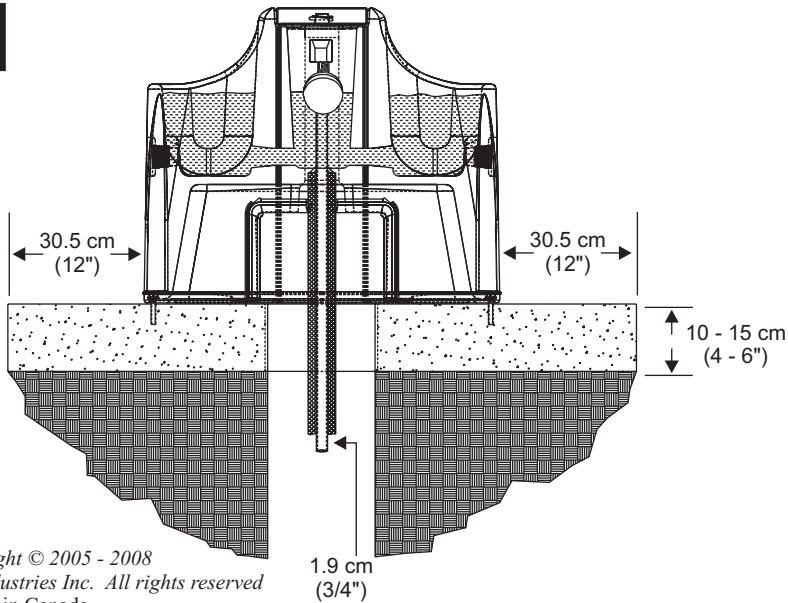

Copyright © 2005 - 2008  
SPi Industries Inc. All rights reserved  
Printed in Canada

Updated: May 20, 2009

## Installation of the Model C-500 Submersible Heater

\* The Model C-500 is safe to use in plastic and structural foam tanks.

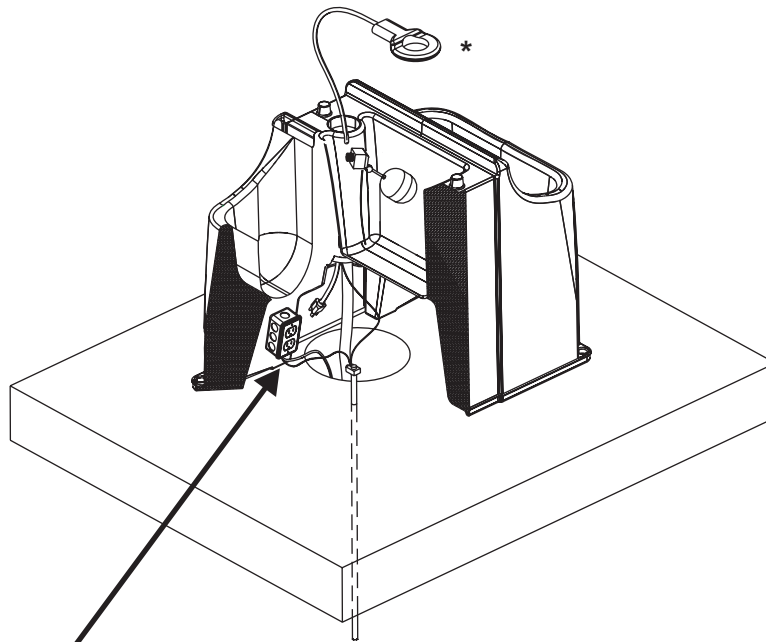

Have a qualified electrician install a properly grounded receptacle outlet, acceptable for outdoor use and protected from the rain and snow

**Incoming Line Heat Tape for VS20E**

1

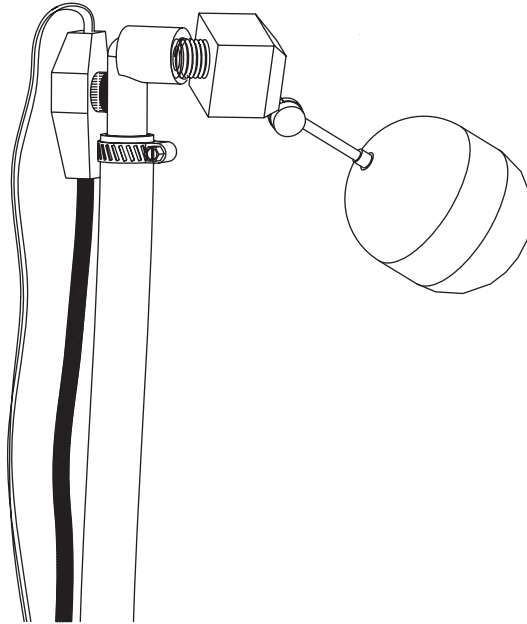

2

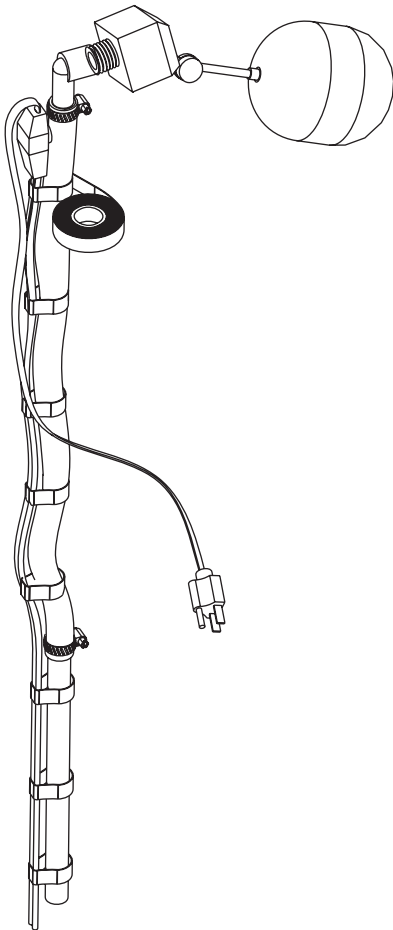

3

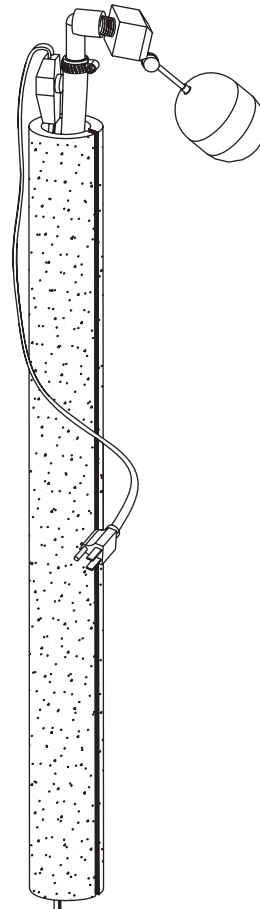

# Warranty Policy



It is the goal of SPI Industries Inc. to provide our customers with the finest in livestock watering equipment products.

SPI provides a 5 (five) year warranty on any purchase of our livestock watering equipment, which includes the models listed below. This warranty covers defects in the material or workmanship. The warranty however, is limited only to the value of the defected part and does not include any freight charges, loss of production and/or changes in operation. It does not cover damage due to careless machine handling and neglect.

<b>Electric Models:</b>	EE10NG; EE50; EE100; VS15E; VS20E; VS20LPE
<b>Energy Free Models:</b>	351NG; 352NG; 354NG
<b>Tip Tanks:</b>	TIPTANK4,NG; TIPTANK7,NG
<b>XL Series:</b>	7XL; 10XL; 12XL
<b>Stock Tanks:</b>	35GALLON;100GALLON;150GALLON

***SPI provides a 1 (One) Year Warranty for:***

- Float and Valve
- Electrical Heating Pad
- Thermostat
- Submersible Heater and Heat Tape

***Note: To ensure the life of your electric livestock waterer be sure that the waterer is drained and shut off when not in use.***

Copyright © 2004 - 2008  
SPI Industries Inc. All rights reserved  
Printed in Canada

Updated: February 2008

Box 100, R.R.#2  
Shallow Lake, ON N0H 2K0 Canada

Tel: 800-269-6533 or 519-935-2211  
Fax: 519-935-2174

Email: [spi@spioplastics.com](mailto:spi@spioplastics.com)  
Web: [www.spioplastics.com](http://www.spioplastics.com)

The SPI logo, consisting of the letters 'SPI' in a bold, black font. It is positioned in the bottom right corner of the page, partially overlapping a dark, stylized graphic element that resembles a water droplet or a splash.