

Installation of the Model C-500 Submersible Heater

* The Model C-500 (240 ac) is safe to use in plastic and structural foam tanks.

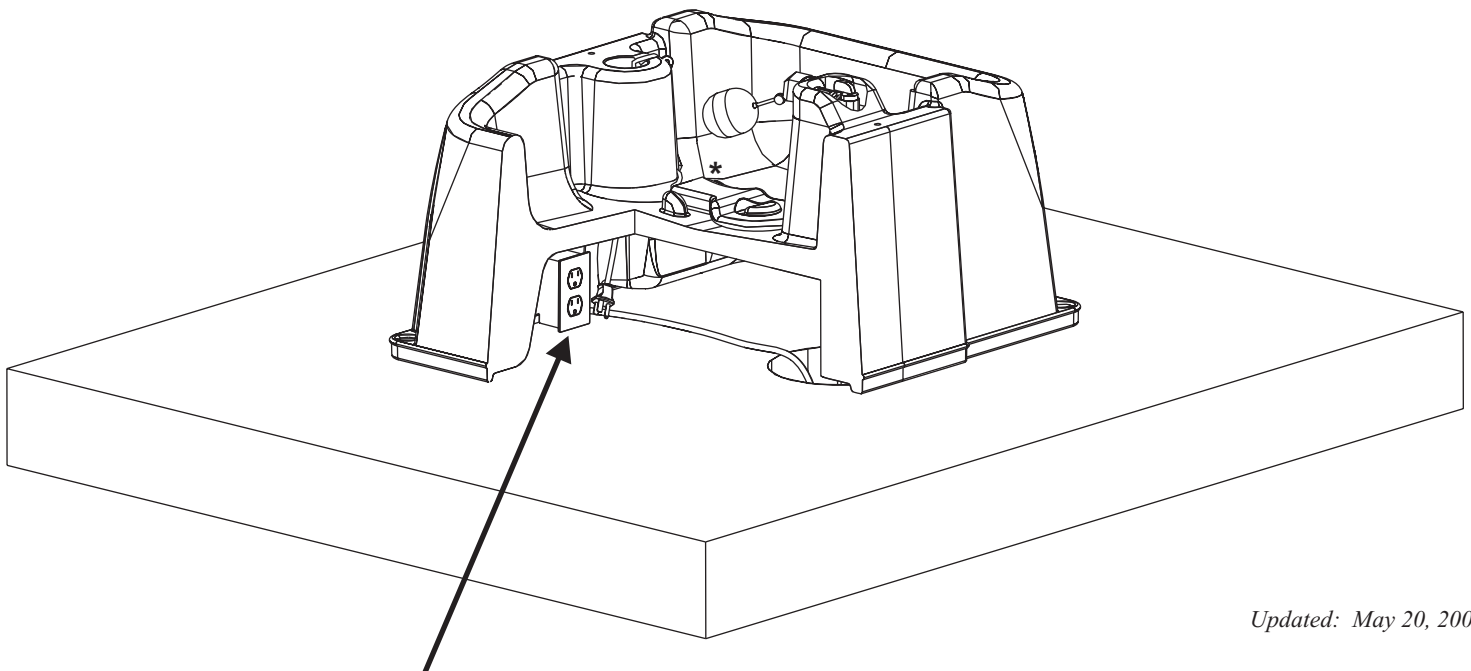

Updated: May 20, 2009

Have a qualified electrician install a properly grounded receptacle outlet, acceptable for outdoor use and protected from the rain and snow.



1

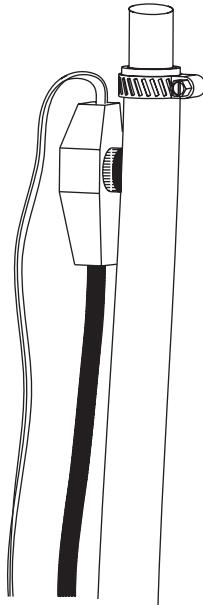

2

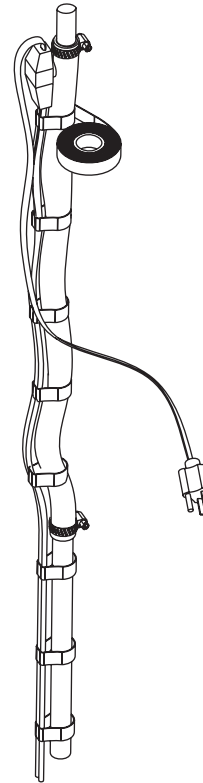

3

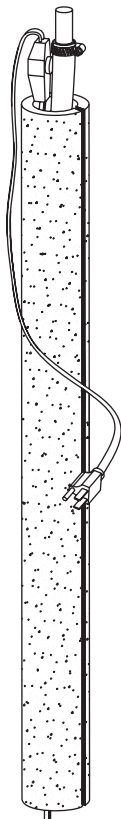

Warranty Policy



It is the goal of SPI Industries Inc. to provide our customers with the finest in livestock watering equipment products.

SPI provides a 5 (five) year warranty on any purchase of our livestock watering equipment, which includes the models listed below. This warranty covers defects in the material or workmanship. The warranty however, is limited only to the value of the defected part and does not include any freight charges, loss of production and/or changes in operation. It does not cover damage due to careless machine handling and neglect.

| | |
|----------------------------|--|
| Electric Models: | EE10NG; EE50; EE100; VS15E; VS20E; VS20LPE |
| Energy Free Models: | 351NG; 352NG; 354NG |
| Tip Tanks: | TIPTANK4,NG; TIPTANK7,NG |
| XL Series: | 7XL; 10XL; 12XL |
| Stock Tanks: | 35GALLON;100GALLON;150GALLON |

SPI provides a 1 (One) Year Warranty for:

- Float and Valve
- Electrical Heating Pad
- Thermostat
- Submersible Heater and Heat Tape

Note: To ensure the life of your electric livestock waterer be sure that the waterer is drained and shut off when not in use.

Copyright © 2004 - 2008
SPI Industries Inc. All rights reserved
Printed in Canada

Updated: February 2008

Box 100, R.R.#2
Shallow Lake, ON N0H 2K0 Canada

Tel: 800-269-6533 or 519-935-2211
Fax: 519-935-2174

Email: spi@spioplastics.com
Web: www.spioplastics.com

A stylized logo for SPI, featuring the letters 'SPI' in a bold, black font. The logo is set against a white background that is part of a larger graphic element on the right side of the page, which includes a silhouette of a cow's head.